

XE80N

Electric Self-propelled Scissor Lift

Mantall®



XE80N Specifications

Dimension

A Max. Platform Height	5.8m	19ft 0in
B Max. Working Height	7.8m	25ft 7in
C Max. Outreach	0.9m	2ft 11in
D Overall Length	1.83m	6ft 0in
E Overall Width	0.77m	2ft 6in
F Overall Height (guardrails folded)	1.86m	6ft 1in
G Overall Height (guardrails unfolded)	2.18m	7ft 2in
J Wheelbase	1.36m	4ft 6in
Ground Clearance	0.08m	0ft 3in
Pothole protection board ground Clearance	0.02m	0ft 1in
Platform Size(L × W × H)	1.64m*0.75m*1.1m	5ft5in×2ft6in×3ft7in
K Length - Platform Extended	2.55m	8ft 4in
M Skirting Board Height	0.15m	0ft 6in

Performance

Lifting Capacity	230kg	507 lb
Lifting Capacity (extended platform)	115kg	254 lb
Max. Load number (indoor)	2 pers	2 pers
Drive Speed (Stowed)	3.8km/h	2.4mph
Drive Speed (Raised)	0.7km/h	0.4mph
Rising Time (empty load)	14s	14s
Lowering Time(empty load)	11s	11s
Gradeability (2WD)	0.25	0.3
Tilt Sensor - Front to Back/ Side to Side	3°/1.5°	3°/1.5°
Turning Radius (inside/ outside)	0.8m/1.56m	3ft/5ft2in
Max. Lateral Force (indoor)	400N	90 lbf
Max. Wind Speed	0	0
Tire Specification/ Type	323mm×100mm/solid tire	12.7in × 3.9in/solid tire

Power

Drive Model	Hydraulic/ Electric Drive, 2WD×2WS	Hydraulic/ Electric Drive, 2WD×2WS
Power Unit Motor (voltage/power)	24V/3.3kW	24V/3.3kW
Hydraulic Tank Capacity	8L	2.1 gal
Hydraulic system pressure	21Mpa	21Mpa
Battery specifications (lead-acid/lithium)	235Ah	235Ah
System Voltage	24V	24V
Control Voltage	24V	24V
Charger (Input Voltage/Output Current)	90-264V/36A	90-264V/36A

Weight

Weight	1542kg	3400 lb
Standard	GB/CE	GB/CE

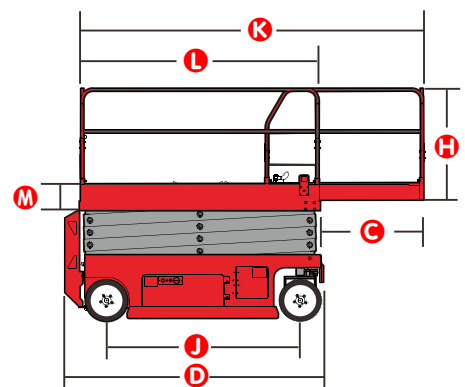
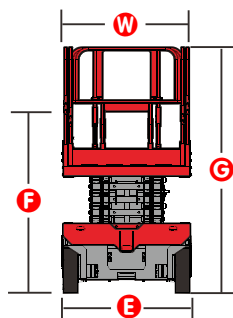
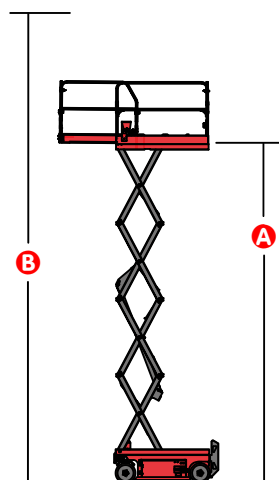

XE80N Advantages and Features

Product Highlights

- ✓ Flexible operation and handling
- ✓ Ultra stable design greatly improves safety factor
- ✓ Featuring compact body, and wide operating area
- ✓ Standard forklift hole, high efficiency for equipment transportation
- ✓ Folding guardrail for convenient transportation

Reduce maintenance costs

- ✓ High universality of components and no pressure on spare parts
- ✓ Double door design, convenient maintenance
- ✓ Faults diagnosis system, displaying fault information for rapid troubleshooting

More reliable performance

- ✓ Multiple protection for lifting circuit, safe and reliable
- ✓ Anti collision strip protection, more effective in preventing scratches and collisions
- ✓ Automatic pothole protection and tilt protection to ensure safe operation

Standard Features

- | | |
|---------------------------------|--------------------------------|
| • Manual emergency lower system | • 2 x 2 drive |
| • Platform swing gate | • Anti collision strip |
| • Extended platform | • Emergency lowering system |
| • Foldable platform | • Tilt alarm |
| • Manual brake release | • Manual box |
| • Non-marking tires | • Emergency stop button |
| • AC power to platform | • Drivable at full height |
| • Buzzer | • Automatic pothole protection |
| • Hour meter | • Flash light |
| • Safety support bar | • Control proportional |
| • charging indicator | • Automatic brake system |
| • Diagnosis system | • Forklift and lifting holes |
| • Maintenance free battery | • Dual flashing beacon |

Options Features

- | | |
|----------------------------|-----------------------------------|
| • Air line to platform | • GPS |
| • Power socket to platform | • Lithium battery |
| • Platform work light | • Top stop sensor |
| • Overload sensor | • Electrophoretic coating process |